

# BARLOW

Flange Isolation Joints

*Manufactured for Current Pipeline Products™,  
a division of IMAC Systems, Inc.*

Nothing  
better  
than

**BARLOW**

Welded into place  
for a permanent  
solution



**CURRENT  
PIPELINE PRODUCTS™**  
*A division of IMAC Systems, Inc.*

[www.imacsystems.com](http://www.imacsystems.com)

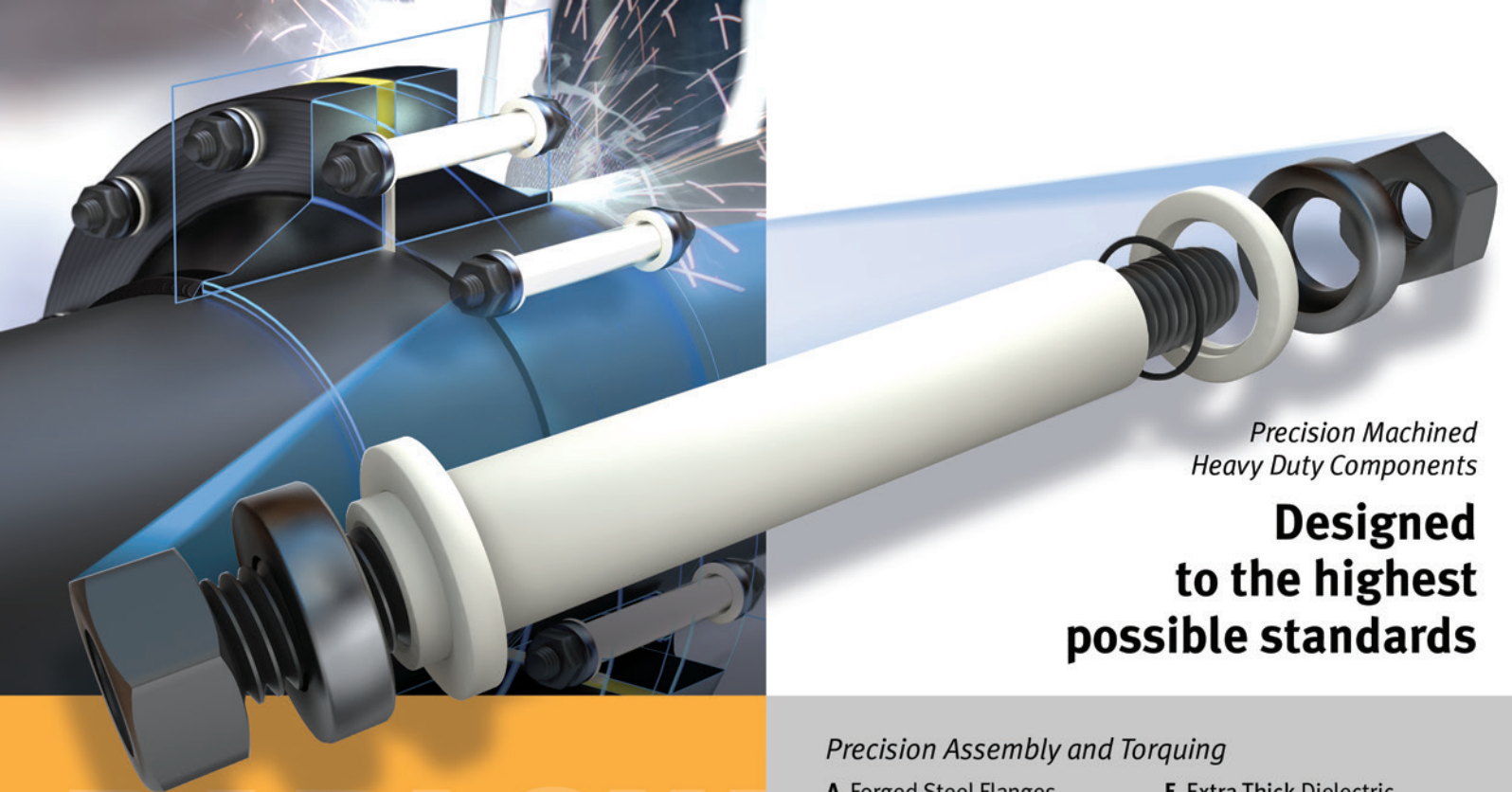

*Precision Machined  
Heavy Duty Components*

**Designed  
to the highest  
possible standards**

# BARLOW

## FEATURES

- Thicker dielectric sleeves (1/8") machined to precise, close tolerance dimensions, both length and diameter.
- Flange bolt holes line reamed to provide perfect alignment and close tolerance fit to the dielectric sleeves.
- Flange studs machined from Alloy Steel and heat treated to ASTM Designation A-193-52T Grade B-7, resulting in superior strength and greater resistance to stress-induced elongation.
- Coupling nuts machined from Alloy Steel and heat treated to ASTM Designation A-194 Class 2-H.
- Precision machined steel washers, flat, parallel, and counterbored allowing for square alignment and clearance for the dielectric sleeves. The clearance prevents load on the sleeves after torquing flange studs.
- Flange gasket precision cut for ideal fit with small projection into the stream to prevent bridging of the joint inside the pipe.
- Precise assembly with accurate torquing carried out in sequential pattern followed by retorquing after 24 hours.
- Flange gap sealed with epoxy resin to prevent contamination and electrical shorting.
- Dielectric strength test (minimum) 5 kV at 50 hz for 1 minute (dry air).
- Electrical resistance test (minimum) 50 MΩ at 1 kV DC (dry air).

### *Precision Assembly and Torquing*

- |                                 |   |
|---------------------------------|---|
| <b>A</b> Forged Steel Flanges   | <b>F</b> Extra Thick Dielectric Washers |
| <b>B</b> Alloy Steel Studs      | <b>G</b> Extra Thick Dielectric Sleeves |
| <b>C</b> Heavy Steel Hex Nuts   | <b>H</b> Epoxy Resin Sealant            |
| <b>D</b> Sealing Gaskets        | <b>I</b> Dielectric Gasket              |
| <b>E</b> Recessed Steel Washers |   |

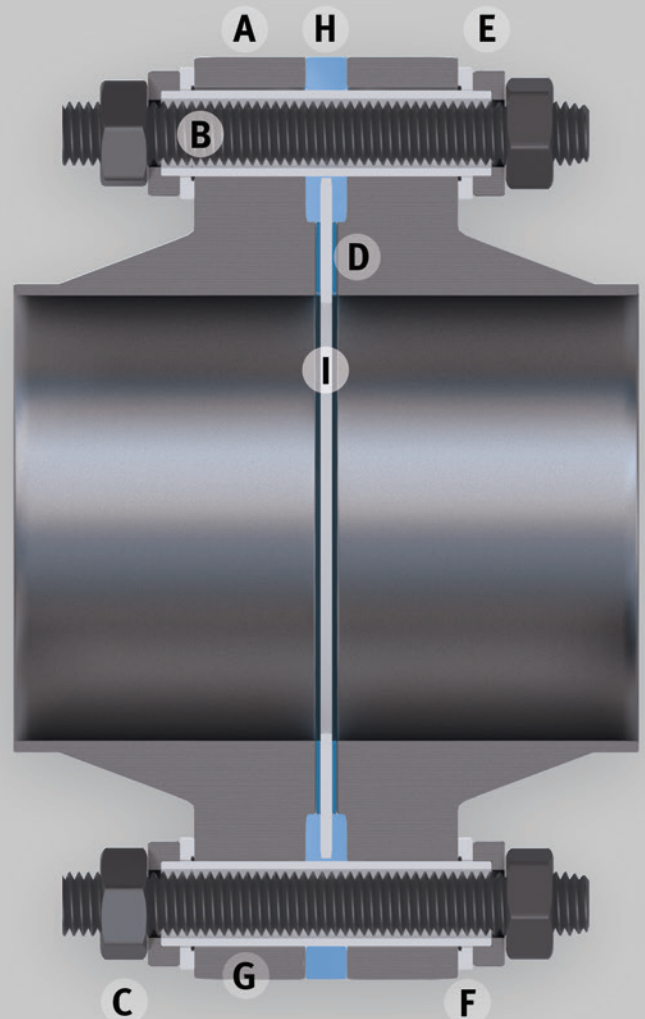

# DIMENSIONS

## Barlow Insulating Joints ANSI 150 Class

PIPE SIZE		FLANGE DIMENSIONS		ALLOY STEEL STUDS			JOINT	AVERAGE WEIGHT
Inches	O.D.	I.D.*	Thickness***	Number	Thread	Length	End to End	Pounds
2	6	2.07	0.69	4	1/2-13	4 1/4	5 3/16	15
3	7 1/2	3.07	0.88	4	1/2-13	4 5/8	5 11/16	27
4	9	4.03	0.88	8	1/2-13	4 5/8	6 3/16	40
6	11	6.07	0.94	8	5/8-11	5	7 3/16	64
8	13 1/2	7.98	1.06	8	5/8-11	5 1/4	8 3/16	96
10	16	10.02	1.12	12	3/4-10	5 5/8	8 3/16	135
12	19	12.00	1.19	12	3/4-10	5 3/4	9 3/16	203
16	23 1/2	15.25	1.38	16	7/8-9	6 5/8	10 3/16	330
20	27 1/2	19.25	1.62	20	1-8	7 3/8	11 9/16	480
24	32	23.25	1.81	20	1 1/8-8	8	12 3/16	656
30	38 3/4	29.25	2.88	28	1 1/8-8	8 1/2	10 15/16	913

## Barlow Insulating Joints ANSI 300 Class

PIPE SIZE		FLANGE DIMENSIONS		ALLOY STEEL STUDS			JOINT	AVERAGE WEIGHT
Inches	O.D.	I.D.*	Thickness***	Number	Thread	Length	End to End	Pounds
2	6 1/2	2.07	0.81	8	1/2-13	4 1/2	5 11/16	23
3	8 1/4	3.07	1.06	8	5/8-11	5 1/4	6 7/16	44
4	10	4.03	1.19	8	5/8-11	5 1/2	6 15/16	61
6	12 1/2	6.07	1.38	12	5/8-11	5 3/4	7 15/16	102
8	15	7.98	1.56	12	3/4-10	6 3/4	8 15/16	156
10	17 1/2	10.02	1.81	16	7/8-9	7 1/2	9 7/16	236
12	20 1/2	12.00	1.94	16	1-8	8	10 7/16	332
16	25 1/2	15.25	2.19	20	1 1/8-8	8 3/4	11 11/16	581
20	30 1/2	19.25	2.44	24	1 1/8-8	9 1/2	12 15/16	901
24	36	23.25	2.69	24	1 3/8-8	10 1/2	13 7/16	1329
30	43	29.25	3.57	28	1 5/8-8	12 1/2	16 11/16	2059

## Barlow Insulating Joints ANSI 600 Class

PIPE SIZE		FLANGE DIMENSIONS		ALLOY STEEL STUDS			JOINT	AVERAGE WEIGHT
Inches	O.D.	I.D.**	Thickness***	Number	Thread	Length	End to End	Pounds
2	6 1/2	1.94	1	8	1/2-13	5 1/4	6 7/16	30
3	8 1/4	2.90	1.25	8	5/8-11	6	7 3/16	53
4	10 3/4	3.83	1.50	8	3/4-10	6 3/4	8 11/16	97
6	14	5.76	1.88	12	7/8-9	8	9 15/16	188
8	16 1/2	7.63	2.19	12	1-8	9	11 3/16	278
10	20	9.75	2.50	16	1 1/8-8	9 3/4	12 11/16	442
12	22	11.75	2.62	20	1 1/8-8	10	12 15/16	532
16	27	15.00	3	20	1 3/8-8	11 1/4	14 11/16	1105
20	32	19.00	3.50	24	1 1/2-8	12 1/2	15 11/16	1608
24	37	23.00	4	24	1 3/4-8	14	16 11/16	2300
30	44 1/2	29.00	4.50	28	1 7/8-8	15 1/2	20 3/16	2920

\*ID for Standard Wall Pipe \*\*ID for Extra Strong Wall Pipe (STD Wall Available Upon Request) \*\*\*Flange thickness does not include raised face thickness  
Other sizes and ratings available upon request. Flange dimensions follow the ANSI B16.5 and ANSI B16.47 Series 'A' specifications.

## ABOUT IMAC SYSTEMS, INC.

# BARLOW Flange Insulated Joints, welded into place for a permanent solution

*Tested and Ready  
for Installation*

**American Made**

Manufacturers and distributors of equipment for the mitigation and control of corrosion, specializing in cathodic protection.

### Why BARLOW Insulated Joints?

1. Factory manufactured BARLOW eliminates kits, no field assembly required
2. Controlled assembly and pretesting eliminates adjustments, eliminates short circuits and guarantees performance
3. Mechanical design resists effects of stress and the resulting insulation failure
4. Every joint has stringent quality control, traceable with a unique, permanently marked serial number
5. Each joint provided with a certificate of testing



Systems, Inc.

International Measurement and Control Systems

90 Main Street, PO Box 1605 • Tullytown, PA 19007

1-800-955-4GAS • Phone: (215) 946-2200 • Fax: (215) 943-2984

Email: [sales@imacsystems.com](mailto:sales@imacsystems.com) [www.imacsystems.com](http://www.imacsystems.com)